

LM2738

LM2738 550kHz/1.6MHz 1.5A Step-Down DC-DC Switching Regulator



Literature Number: SNVS556A

LM2738

550kHz/1.6MHz 1.5A Step-Down DC-DC Switching Regulator

General Description

The LM2738 regulator is a monolithic, high frequency, PWM step-down DC/DC converter in an 8-pin LLP or 8-pin eMSOP package. It provides all the active functions for local DC/DC conversion with fast transient response and accurate regulation in the smallest possible PCB area.

With a minimum of external components, the LM2738 is easy to use. The ability to drive 1.5A loads with an internal 250mΩ NMOS switch using state-of-the-art 0.5μm BiCMOS technology results in the best power density available. Switching frequency is internally set to 550kHz (LM2738Y) or 1.6MHz (LM2738X), allowing the use of extremely small surface mount inductors and chip capacitors. Even though the operating frequencies are very high, efficiencies up to 90% are easy to achieve. External enable is included, featuring an ultra-low stand-by current of 400nA. The LM2738 utilizes current-mode control and internal compensation to provide high-performance regulation over a wide range of operating conditions. Additional features include internal soft-start circuitry to reduce in-rush current, cycle-by-cycle current limit, thermal shutdown, and output over-voltage protection.

Features

- Space Saving LLP-8 and eMSOP-8 package
- 3.0V to 20V input voltage range
- 0.8V to 18V output voltage range
- 1.5A output current
- 550kHz (LM2738Y) and 1.6MHz (LM2738X) switching frequencies
- 250mΩ NMOS switch
- 400nA shutdown current
- 0.8V, 2% internal voltage reference
- Internal soft-start
- Current-Mode, PWM operation
- Thermal shutdown

Applications

- Local Point of Load Regulation
- Core Power in HDDs
- Set-Top Boxes
- Battery Powered Devices
- USB Powered Devices
- DSL Modems

Typical Application Circuit

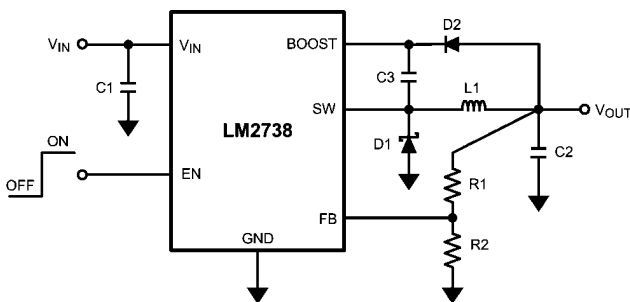

30049101

Efficiency vs Load Current

$V_{IN} = 12V, V_{OUT} = 3.3V$

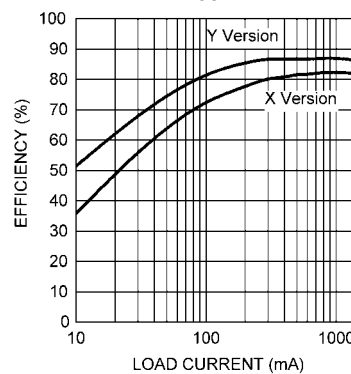

30049145

Connection Diagrams

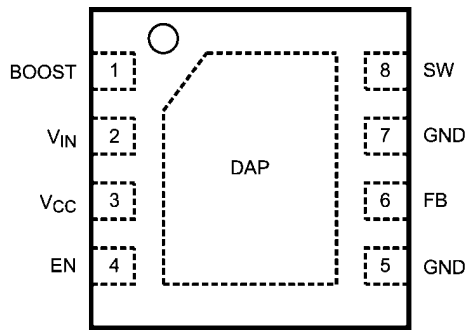

8-Pin LLP - TOP VIEW
NS Package Number SDA08A

30049161

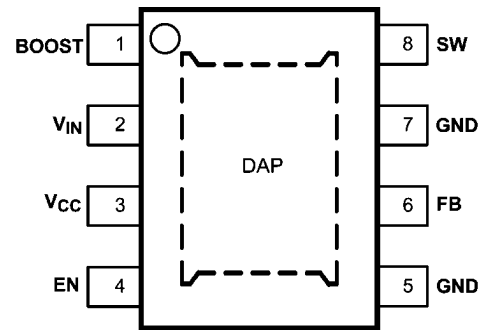

8-Pin eMSOP - TOP VIEW
NS Package Number MUY08A

30049163

Ordering Information

Order Number	Frequency Option	Package Type	NSC Package Drawing	Package Marking	Supplied As
LM2738XSD	1.6MHz	8-Lead LLP	SDA08A	L237B	1000 Tape and Reel
LM2738XSDX					4500 Tape and Reel
LM2738YSD	0.55MHz			L174B	1000 Tape and Reel
LM2738YSDX					4500 Tape and Reel
LM2738XMY	1.6MHz	8-Lead eMSOP	MUY08A	STDB	1000 Tape and Reel
LM2738XMYX					3500 Tape and Reel
LM2738YMY	0.55MHz			SJBB	1000 Tape and Reel
LM2738YMYX					3500 Tape and Reel

* Contact the local sales office for the lead-free package.

Pin Descriptions

Pin	Name	Function
1	BOOST	Boost voltage that drives the internal NMOS control switch. A bootstrap capacitor is connected between the BOOST and SW pins.
2	V_{IN}	Supply voltage for output power stage. Connect a bypass capacitor to this pin. Must tie pins 2 and 3 together at package.
3	V_{CC}	Input supply voltage of the IC. Connect a bypass capacitor to this pin. Must tie pin 2 and 3 together at the package.
4	EN	Enable control input. Logic high enables operation. Do not allow this pin to float or be greater than $V_{IN} + 0.3V$.
5, 7	GND	Signal and power ground pins. Place the bottom resistor of the feedback network as close as possible to these pins.
6	FB	Feedback pin. Connect FB to the external resistor divider to set output voltage.
8	SW	Output switch. Connects to the inductor, catch diode, and bootstrap capacitor.
DAP	GND	Signal and power ground. Must be connected to GND on the PCB.

Absolute Maximum Ratings *(Note 1)*

If Military/Aerospace specified devices are required, please contact the National Semiconductor Sales Office/Distributors for availability and specifications.

V_{IN}, V_{CC}	-0.5V to 24V
SW Voltage	-0.5V to 24V
Boost Voltage	-0.5V to 30V
Boost to SW Voltage	-0.5V to 6.0V
FB Voltage	-0.5V to 3.0V
EN Voltage	-0.5V to ($V_{IN} + 0.3V$)
Junction Temperature	150°C
ESD Susceptibility <i>(Note 2)</i>	2kV
Storage Temp. Range	-65°C to 150°C

Soldering Information

Infrared/Convection Reflow (15sec)	220°C
Wave Soldering Lead Temp. (10sec)	260°C

Operating Ratings *(Note 1)*

V_{IN}, V_{CC}	3V to 20V
SW Voltage	-0.5V to 20V
Boost Voltage	-0.5V to 25.5V
Boost to SW Voltage	2.5V to 5.5V
Junction Temperature Range	-40°C to +125°C
Thermal Resistance θ_{JA} for LLP/eMSOP <i>(Note 3)</i>	60°C/W
Thermal Shutdown <i>(Note 3)</i>	165°C

Electrical Characteristics

Specifications with standard typeface are for $T_J = 25^\circ\text{C}$, and those in **boldface type** apply over the full **Operating Temperature Range** ($T_J = -40^\circ\text{C}$ to 125°C). $V_{IN} = 12V$, $V_{BOOST} - V_{SW} = 5V$ unless otherwise specified. Datasheet min/max specification limits are guaranteed by design, test, or statistical analysis.

Symbol	Parameter	Conditions	Min <i>(Note 4)</i>	Typ <i>(Note 5)</i>	Max <i>(Note 4)</i>	Units
V_{FB}	Feedback Voltage		0.784	0.800	0.816	V
$\Delta V_{FB}/\Delta V_{IN}$	Feedback Voltage Line Regulation	$V_{IN} = 3V$ to 20V		0.02		% / V
I_{FB}	Feedback Input Bias Current	Sink/Source		0.1	100	nA
UVLO	Undervoltage Lockout	V_{IN} Rising		2.7	2.90	V
	Undervoltage Lockout	V_{IN} Falling	2.0	2.3		
	UVLO Hysteresis			0.4		
F_{SW}	Switching Frequency	LM2738X	1.28	1.6	1.92	MHz
		LM2738Y	0.364	0.55	0.676	
D_{MAX}	Maximum Duty Cycle	LM2738X, Load=150mA		92		%
		LM2738Y, Load=150mA		95		
D_{MIN}	Minimum Duty Cycle	LM2738X		7.5		%
		LM2738Y		2		
$R_{DS(ON)}$	Switch ON Resistance	$V_{BOOST} - V_{SW} = 3V$, Load=400mA		250	500	m Ω
I_{CL}	Switch Current Limit	$V_{BOOST} - V_{SW} = 3V$, $V_{IN} = 3V$	2.0	2.9		A
I_Q	Quiescent Current	Switching		1.9	3	mA
		Non-Switching		1.9		mA
	Quiescent Current (shutdown)	$V_{EN} = 0V$		400		nA
I_{BOOST}	Boost Pin Current	LM2738X (27% Duty Cycle)		4.5		mA
		LM2738Y (27% Duty Cycle)		2.5		
V_{EN_TH}	Shutdown Threshold Voltage	V_{EN} Falling		-	0.4	V
	Enable Threshold Voltage	V_{EN} Rising	1.4	-		
I_{EN}	Enable Pin Current	Sink/Source		10		nA
I_{SW}	Switch Leakage	$V_{IN} = 20V$		100		nA

Note 1: Absolute Maximum Ratings indicate limits beyond which damage to the device may occur. Operating Ratings indicate conditions for which the device is intended to be functional, but specific performance is not guaranteed. For guaranteed specifications and the test conditions, see Electrical Characteristics.

Note 2: Human body model, 1.5k Ω in series with 100pF.

Note 3: Typical thermal shutdown will occur if the junction temperature exceeds 165°C. The maximum power dissipation is a function of $T_{J(MAX)}$, θ_{JA} and T_A . The maximum allowable power dissipation at any ambient temperature is $P_D = (T_{J(MAX)} - T_A)/\theta_{JA}$. All numbers apply for packages soldered directly onto a 3" x 3" PC board with 2 oz. copper on 4 layers in still air in accordance to JEDEC standards. Thermal resistance varies greatly with layout, copper thickness, number of layers in PCB, power distribution, number of thermal vias, board size, ambient temperature, and air flow.

Note 4: Guaranteed to National's Average Outgoing Quality Level (AOQL).

Note 5: Typicals represent the most likely parametric norm.

Typical Performance Characteristics

unless specified otherwise.

All curves taken at $V_{IN} = 12V$, $V_{BOOST} - V_{SW} = 5V$, and $T_A = 25^\circ C$,

Efficiency vs Load Current - "X" $V_{OUT} = 5V$

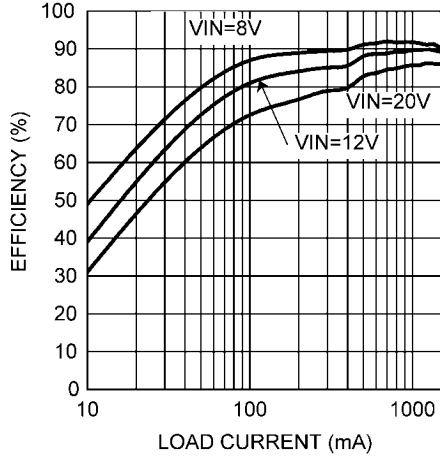

Efficiency vs Load Current - "Y" $V_{OUT} = 5V$

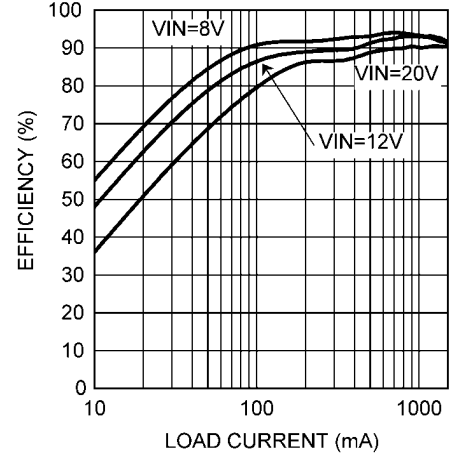

Efficiency vs Load Current - "X" $V_{OUT} = 3.3V$

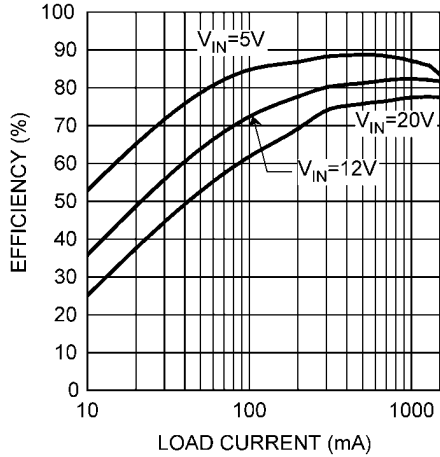

Efficiency vs Load Current - "Y" $V_{OUT} = 3.3V$

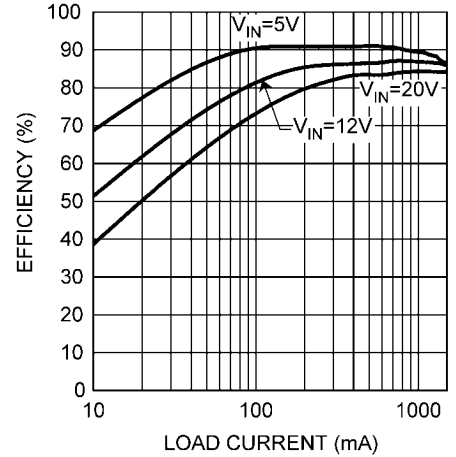

Efficiency vs Load Current - "X" $V_{OUT} = 1.5V$

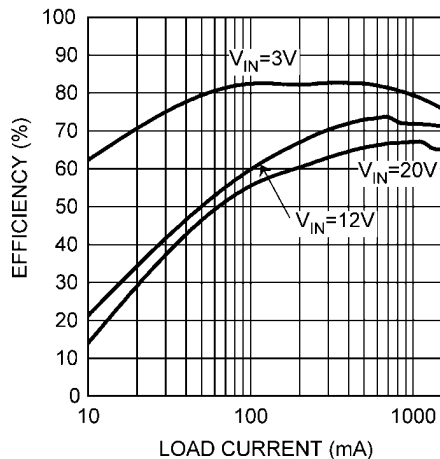

Efficiency vs Load Current - "Y" $V_{OUT} = 1.5V$

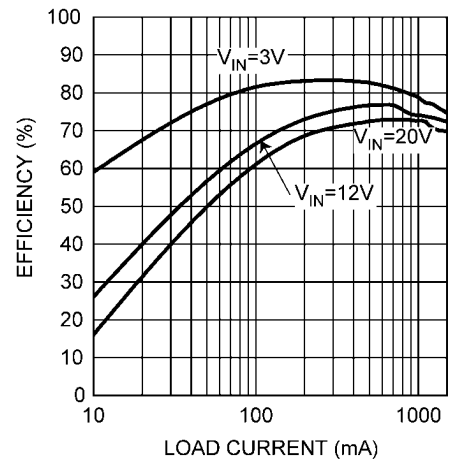

Typical Performance Characteristics

unless specified otherwise.

All curves taken at $V_{IN} = 12V$, $V_{BOOST} - V_{SW} = 5V$, and $T_A = 25^\circ C$,

Oscillator Frequency vs Temperature - "X"

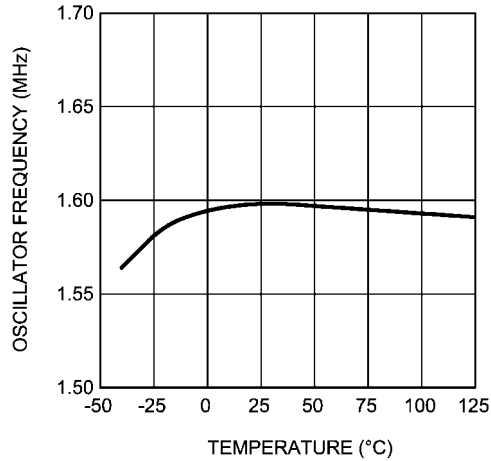

30049127

Oscillator Frequency vs Temperature - "Y"

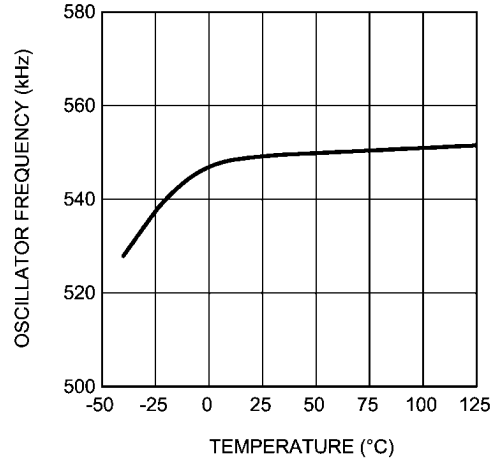

30049128

Current Limit vs Temperature $V_{IN} = 5V$

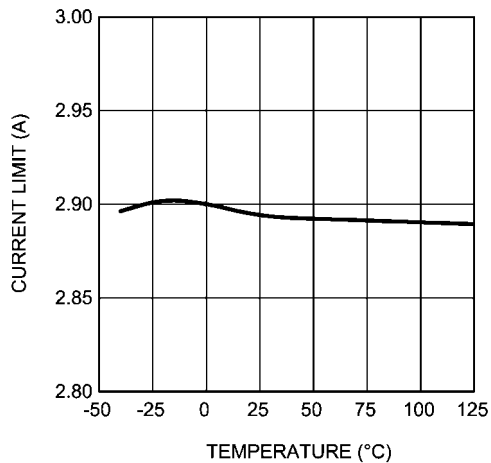

30049129

I_Q Non-Switching vs Temperature

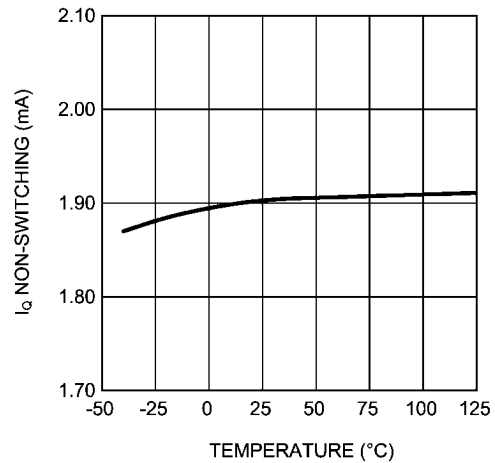

30049147

V_{FB} vs Temperature

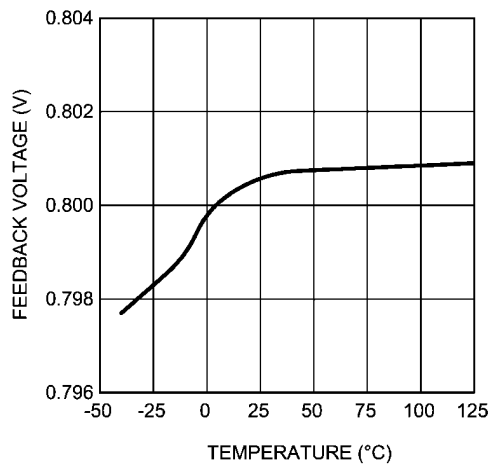

30049133

$R_{DS(ON)}$ vs Temperature

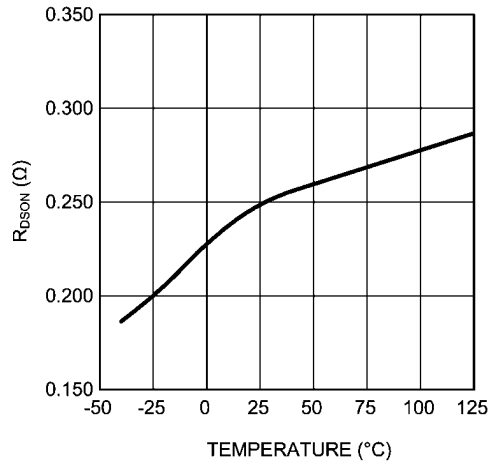

30049130

Typical Performance Characteristics

unless specified otherwise.

All curves taken at $V_{IN} = 12V$, $V_{BOOST} - V_{SW} = 5V$, and $T_A = 25^\circ C$,

Line Regulation - "X" ($V_{OUT} = 1.5V$, $I_{OUT} = 750mA$)

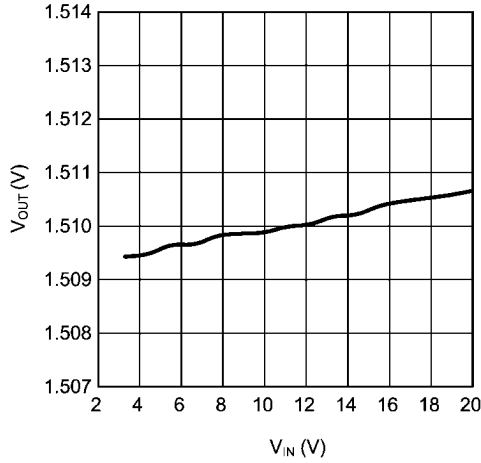

30049156

Line Regulation - "Y" ($V_{OUT} = 1.5V$, $I_{OUT} = 750mA$)

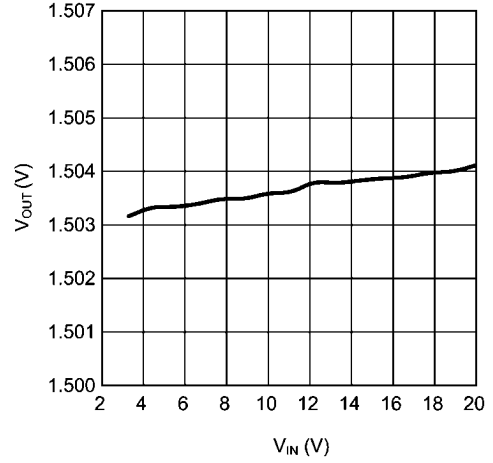

30049154

Line Regulation - "X" ($V_{OUT} = 3.3V$, $I_{OUT} = 750mA$)

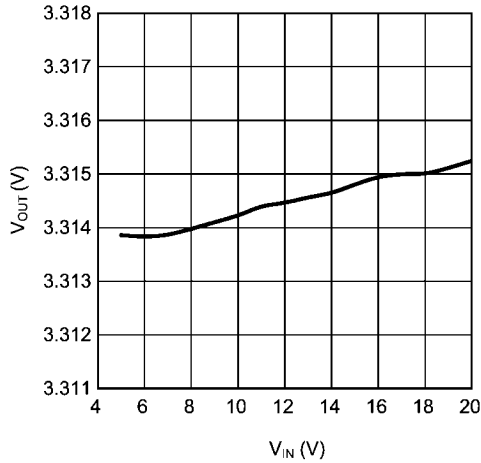

30049155

Line Regulation - "Y" ($V_{OUT} = 3.3V$, $I_{OUT} = 750mA$)

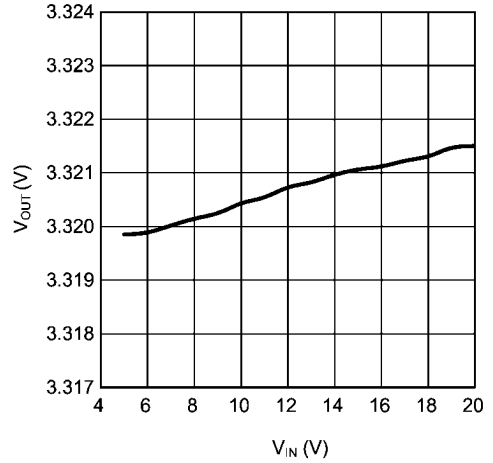

30049153

Load Regulation - "X" ($V_{OUT} = 1.5V$)

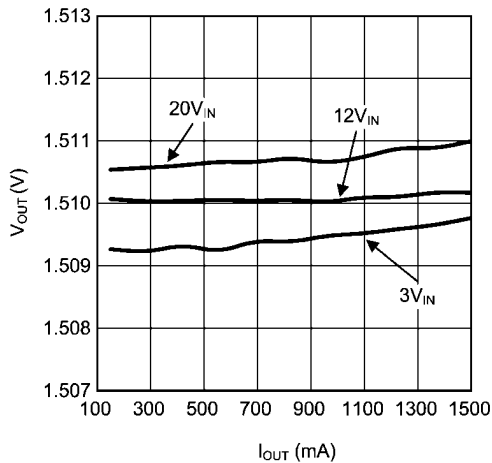

30049176

Load Regulation - "Y" ($V_{OUT} = 1.5V$)

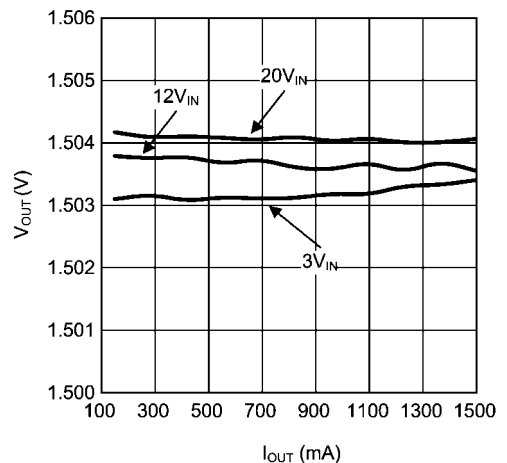

30049175

Typical Performance Characteristics

unless specified otherwise.

All curves taken at $V_{IN} = 12V$, $V_{BOOST} - V_{SW} = 5V$, and $T_A = 25^\circ C$,

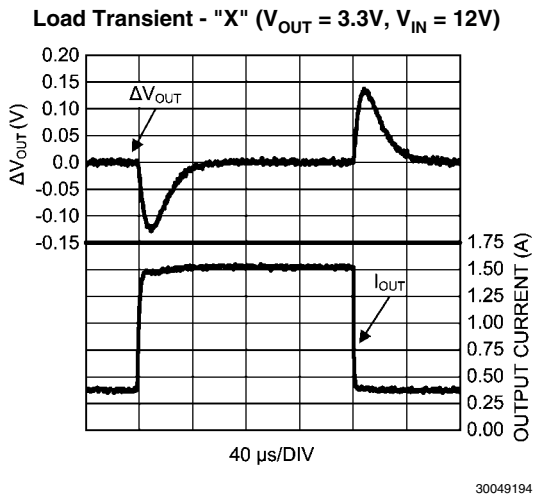
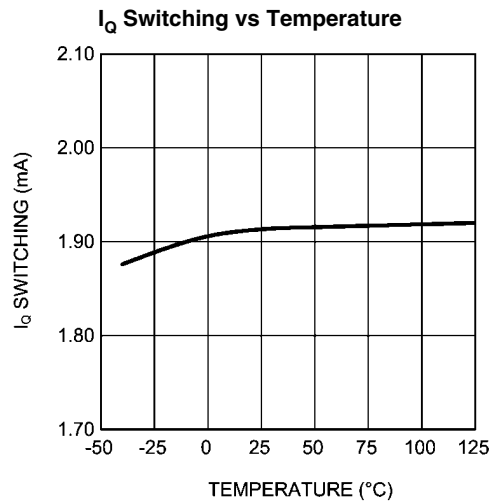
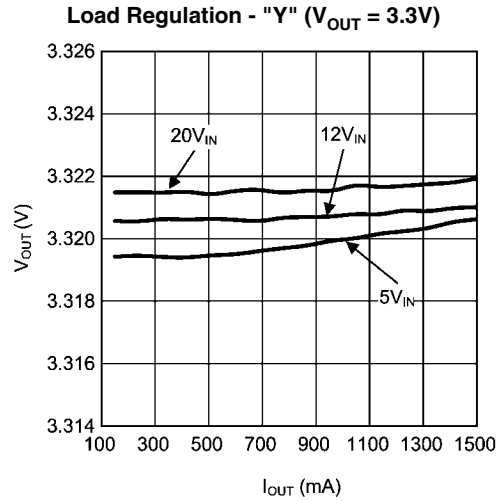
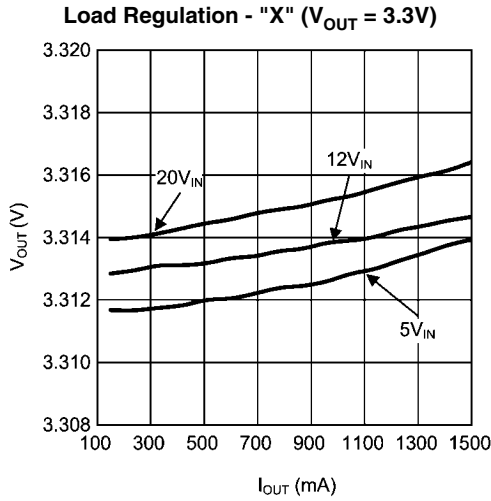

Startup - "X"
 ($V_{OUT} = 3.3V$, $V_{IN} = 12V$, $I_{OUT} = 1.5A$ (Resistive Load))

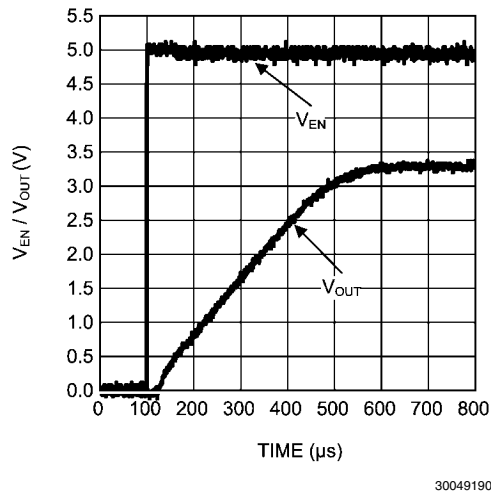

In-Rush Current - "X"
 ($V_{OUT} = 3.3V$, $V_{IN} = 12V$, $I_{OUT} = 1.5A$ (Resistive Load))

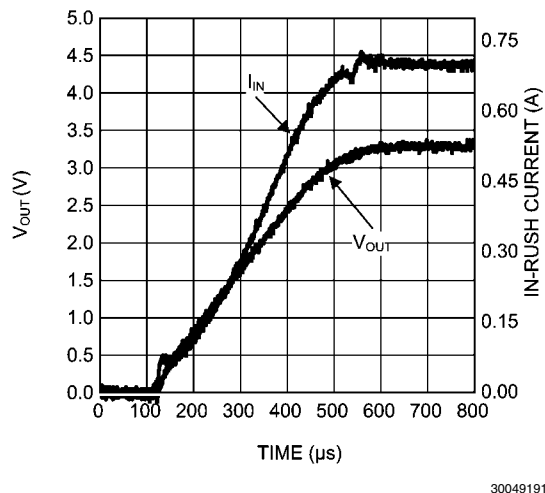

Block Diagram

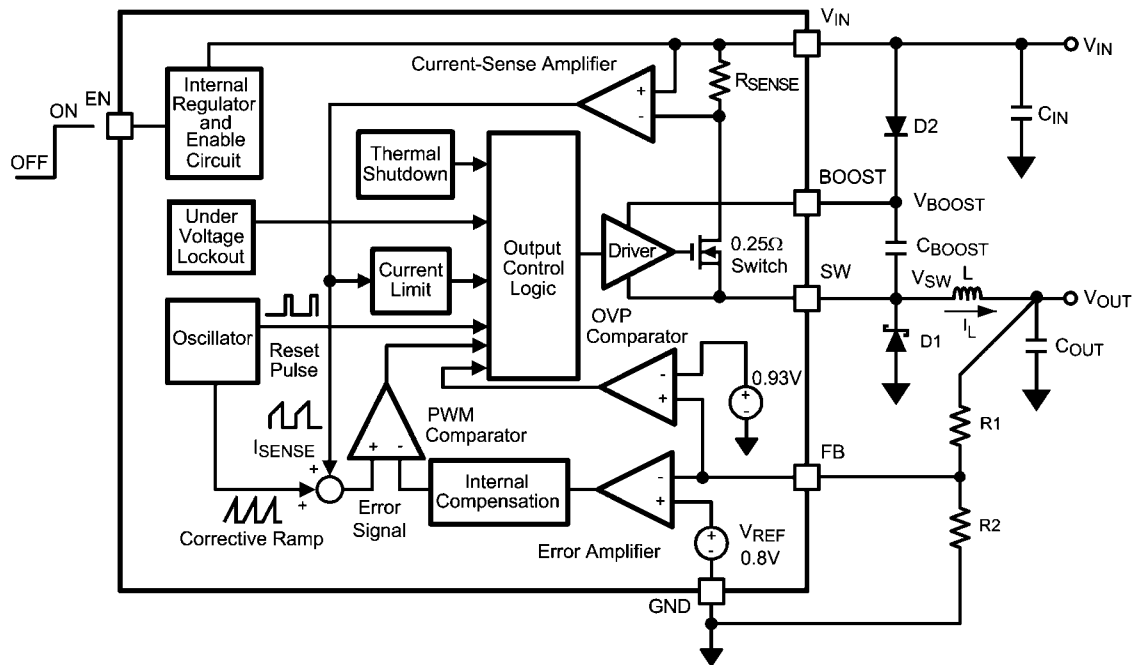

30049106

FIGURE 1. Simplified Internal Block Diagram

Application Information

THEORY OF OPERATION

The LM2738 is a constant frequency PWM buck regulator IC that delivers a 1.5A load current. The regulator has a preset switching frequency of either 550kHz (LM2738Y) or 1.6MHz (LM2738X). These high frequencies allow the LM2738 to operate with small surface mount capacitors and inductors, resulting in DC/DC converters that require a minimum amount of board space. The LM2738 is internally compensated, so it is simple to use, and requires few external components. The LM2738 uses current-mode control to regulate the output voltage.

The following operating description of the LM2738 will refer to the Simplified Block Diagram (Figure 1) and to the waveforms in Figure 2. The LM2738 supplies a regulated output voltage by switching the internal NMOS control switch at constant frequency and variable duty cycle. A switching cycle begins at the falling edge of the reset pulse generated by the internal oscillator. When this pulse goes low, the output control logic turns on the internal NMOS control switch. During this on-time, the SW pin voltage (V_{SW}) swings up to approximately V_{IN} , and the inductor current (I_L) increases with a linear slope. I_L is measured by the current-sense amplifier, which generates an output proportional to the switch current. The sense signal is summed with the regulator's corrective ramp and compared to the error amplifier's output, which is proportional to the difference between the feedback voltage and V_{REF} . When the PWM comparator output goes high, the output switch turns off until the next switching cycle begins. During the switch off-time, inductor current discharges through Schottky diode D1, which forces the SW pin to swing

below ground by the forward voltage (V_D) of the catch diode. The regulator loop adjusts the duty cycle (D) to maintain a constant output voltage.

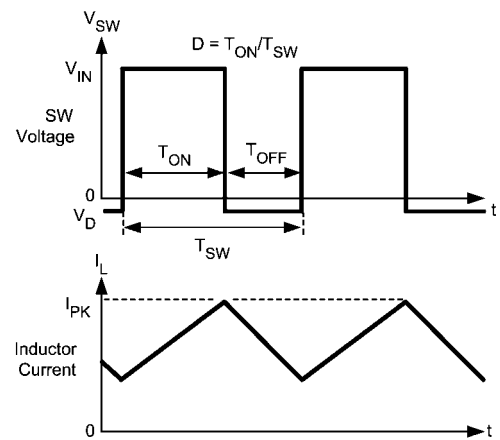

30049107

FIGURE 2. LM2738 Waveforms of SW Pin Voltage and Inductor Current

BOOST FUNCTION

Capacitor C_{BOOST} and diode D2 in Figure 3 are used to generate a voltage V_{BOOST} . $V_{BOOST} - V_{SW}$ is the gate drive voltage to the internal NMOS control switch. To properly drive the internal NMOS switch during its on-time, V_{BOOST} needs to be at least 2.5V greater than V_{SW} . It is recommended that V_{BOOST} be greater than 2.5V above V_{SW} for best efficiency. $V_{BOOST} - V_{SW}$ should not exceed the maximum operating limit of 5.5V.

$5.5V > V_{BOOST} - V_{SW} > 2.5V$ for best performance.

When the LM2738 starts up, internal circuitry from the BOOST pin supplies a maximum of 20mA to C_{BOOST} . This current charges C_{BOOST} to a voltage sufficient to turn the switch on. The BOOST pin will continue to source current to C_{BOOST} until the voltage at the feedback pin is greater than 0.76V.

There are various methods to derive V_{BOOST} :

1. From the input voltage ($3.0V < V_{IN} < 5.5V$)
2. From the output voltage ($2.5V < V_{OUT} < 5.5V$)
3. From an external distributed voltage rail ($2.5V < V_{EXT} < 5.5V$)
4. From a shunt or series zener diode

In the Simplified Block Diagram of [Figure 1](#), capacitor C_{BOOST} and diode D2 supply the gate-drive voltage for the NMOS switch. Capacitor C_{BOOST} is charged via diode D2 by V_{IN} . During a normal switching cycle, when the internal NMOS control switch is off (T_{OFF}) (refer to [Figure 2](#)), V_{BOOST} equals V_{IN} minus the forward voltage of D2 (V_{FD2}), during which the current in the inductor (L) forward biases the Schottky diode D1 (V_{FD1}). Therefore the voltage stored across C_{BOOST} is

$$V_{BOOST} - V_{SW} = V_{IN} - V_{FD2} + V_{FD1}$$

When the NMOS switch turns on (T_{ON}), the switch pin rises to

$$V_{SW} = V_{IN} - (R_{DS(ON)} \times I_L),$$

forcing V_{BOOST} to rise thus reverse biasing D2. The voltage at V_{BOOST} is then

$$V_{BOOST} = 2V_{IN} - (R_{DS(ON)} \times I_L) - V_{FD2} + V_{FD1}$$

which is approximately

$$2V_{IN} - 0.4V$$

for many applications. Thus the gate-drive voltage of the NMOS switch is approximately

$$V_{IN} - 0.2V$$

An alternate method for charging C_{BOOST} is to connect D2 to the output as shown in [Figure 3](#). The output voltage should be between 2.5V and 5.5V, so that proper gate voltage will be applied to the internal switch. In this circuit, C_{BOOST} provides a gate drive voltage that is slightly less than V_{OUT} .

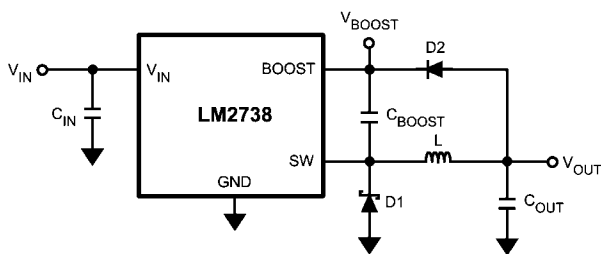

FIGURE 3. V_{OUT} Charges C_{BOOST}

In applications where both V_{IN} and V_{OUT} are greater than 5.5V, or less than 3V, C_{BOOST} cannot be charged directly from these voltages. If V_{IN} and V_{OUT} are greater than 5.5V, C_{BOOST} can be charged from V_{IN} or V_{OUT} minus a zener voltage by placing a zener diode D3 in series with D2, as shown in [Figure 4](#). When using a series zener diode from the input, ensure that the regulation of the input supply doesn't create a voltage that falls outside the recommended V_{BOOST} voltage.

$$(V_{INMAX} - V_{D3}) < 5.5V$$

$$(V_{INMIN} - V_{D3}) > 2.5V$$

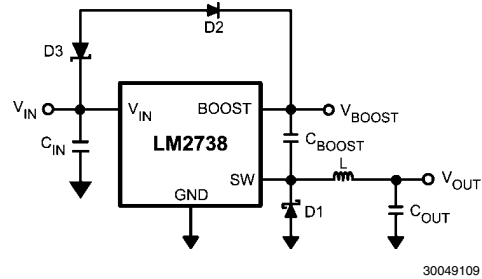

FIGURE 4. Zener Reduces Boost Voltage from V_{IN}

An alternative method is to place the zener diode D3 in a shunt configuration as shown in [Figure 5](#). A small 350mW to 500mW 5.1V zener in a SOT-23 or SOD package can be used for this purpose. A small ceramic capacitor such as a 6.3V, 0.1 μ F capacitor (C_4) should be placed in parallel with the zener diode. When the internal NMOS switch turns on, a pulse of current is drawn to charge the internal NMOS gate capacitance. The 0.1 μ F parallel shunt capacitor ensures that the V_{BOOST} voltage is maintained during this time.

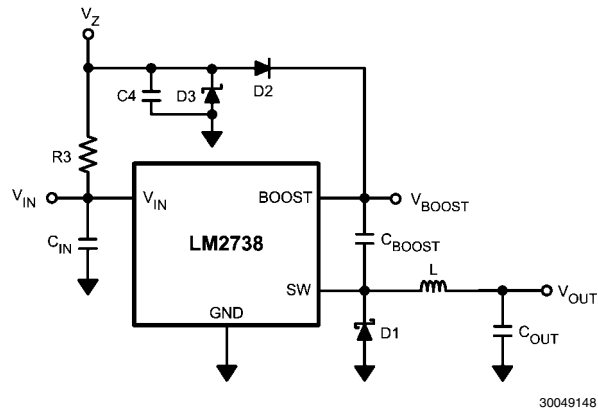

FIGURE 5. Boost Voltage Supplied from the Shunt Zener on V_{IN}

Resistor R3 should be chosen to provide enough RMS current to the zener diode (D3) and to the BOOST pin. A recommended choice for the zener current (I_{ZENER}) is 1 mA. The current I_{BOOST} into the BOOST pin supplies the gate current of the NMOS control switch and varies typically according to the following formula for the X version:

$$I_{BOOST} = 0.56 \times (D + 0.54) \times (V_{ZENER} - V_{D2}) \text{ mA}$$

I_{BOOST} can be calculated for the Y version using the following:

$$I_{BOOST} = 0.22 \times (D + 0.54) \times (V_{ZENER} - V_{D2}) \mu\text{A}$$

where D is the duty cycle, V_{ZENER} and V_{D2} are in volts, and I_{BOOST} is in milliamps. V_{ZENER} is the voltage applied to the anode of the boost diode (D2), and V_{D2} is the average forward voltage across D2. Note that this formula for I_{BOOST} gives typical current. For the worst case I_{BOOST} , increase the current by 40%. In that case, the worst case boost current will be

$$I_{BOOST-MAX} = 1.4 \times I_{BOOST}$$

R3 will then be given by

$$R3 = (V_{IN} - V_{ZENER}) / (1.4 \times I_{BOOST} + I_{ZENER})$$

For example, using the X-version let $V_{IN} = 10V$, $V_{ZENER} = 5V$, $V_{D2} = 0.7V$, $I_{ZENER} = 1mA$, and duty cycle $D = 50\%$. Then

$$I_{BOOST} = 0.56 \times (0.5 + 0.54) \times (5 - 0.7) \text{ mA} = 2.5\text{mA}$$

$$R3 = (10V - 5V) / (1.4 \times 2.5\text{mA} + 1\text{mA}) = 1.11\text{k}\Omega$$

ENABLE PIN / SHUTDOWN MODE

The LM2738 has a shutdown mode that is controlled by the enable pin (EN). When a logic low voltage is applied to EN, the part is in shutdown mode and its quiescent current drops to typically 400nA. The voltage at this pin should never exceed $V_{IN} + 0.3V$.

SOFT-START

This function forces V_{OUT} to increase at a controlled rate during start up. During soft-start, the error amplifier's reference voltage ramps from 0V to its nominal value of 0.8V in approximately 600 μ s. This forces the regulator output to ramp up in a more linear and controlled fashion, which helps reduce inrush current.

OUTPUT OVERVOLTAGE PROTECTION

The overvoltage comparator compares the FB pin voltage to a voltage that is 16% higher than the internal reference V_{ref} . Once the FB pin voltage goes 16% above the internal reference, the internal NMOS control switch is turned off, which allows the output voltage to decrease toward regulation.

UNDERVOLTAGE LOCKOUT

Undervoltage lockout (UVLO) prevents the LM2738 from operating until the input voltage exceeds 2.7V (typ).

The UVLO threshold has approximately 400mV of hysteresis, so the part will operate until V_{IN} drops below 2.3V (typ). Hysteresis prevents the part from turning off during power up if the V_{IN} ramp-up is non-monotonic.

CURRENT LIMIT

The LM2738 uses cycle-by-cycle current limiting to protect the output switch. During each switching cycle, a current limit comparator detects if the output switch current exceeds 2.9A (typ), and turns off the switch until the next switching cycle begins.

THERMAL SHUTDOWN

Thermal shutdown limits total power dissipation by turning off the output switch when the IC junction temperature exceeds 165°C. After thermal shutdown occurs, the output switch doesn't turn on until the junction temperature drops to approximately 150°C.

Design Guide

INDUCTOR SELECTION

The Duty Cycle (D) can be approximated quickly using the ratio of output voltage (V_O) to input voltage (V_{IN}):

$$D = \frac{V_O}{V_{IN}}$$

The catch diode (D1) forward voltage drop and the voltage drop across the internal NMOS switch must be included to calculate a more accurate duty cycle. Calculate D by using the following formula:

$$D = \frac{V_O + V_D}{V_{IN} + V_D - V_{SW}}$$

V_{SW} can be approximated by:

$$V_{SW} = I_{OUT} \times R_{DSON}$$

The diode forward drop (V_D) can range from 0.3V to 0.7V depending on the quality of the diode. The lower the V_D , the higher the operating efficiency of the converter. The inductor value determines the output ripple current. Lower inductor values decrease the size of the inductor, but increase the output ripple current. An increase in the inductor value will decrease the output ripple current.

One must ensure that the minimum current limit (2.0A) is not exceeded, so the peak current in the inductor must be calculated. The peak current (I_{LPK}) in the inductor is calculated by:

$$I_{LPK} = I_{OUT} + \Delta i_L$$

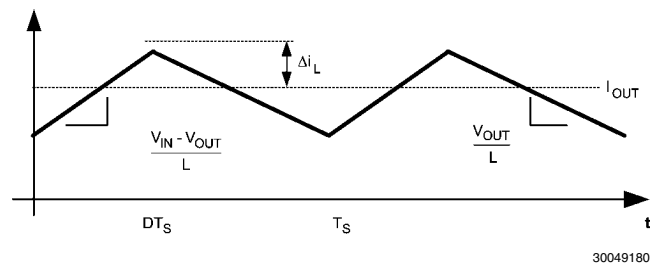

FIGURE 6. Inductor Current

$$\frac{V_{IN} - V_{OUT}}{L} = \frac{2\Delta i_L}{DT_S}$$

In general,

$$\Delta i_L = 0.1 \times (I_{OUT}) \rightarrow 0.2 \times (I_{OUT})$$

If $\Delta i_L = 33.3\%$ of 1.50A, the peak current in the inductor will be 2.0A. The minimum guaranteed current limit over all operating conditions is 2.0A. One can either reduce Δi_L , or make the engineering judgment that zero margin will be safe enough. The typical current limit is 2.9A.

The LM2738 operates at frequencies allowing the use of ceramic output capacitors without compromising transient response. Ceramic capacitors allow higher inductor ripple without significantly increasing output ripple. See the output capacitor section for more details on calculating output voltage ripple. Now that the ripple current is determined, the inductance is calculated by:

$$L = \left(\frac{DT_S}{2\Delta i_L} \right) \times (V_{IN} - V_{OUT})$$

Where

$$T_S = \frac{1}{f_S}$$

When selecting an inductor, make sure that it is capable of supporting the peak output current without saturating. Inductor saturation will result in a sudden reduction in inductance and prevent the regulator from operating correctly. Because

of the speed of the internal current limit, the peak current of the inductor need only be specified for the required maximum output current. For example, if the designed maximum output current is 1.0A and the peak current is 1.25A, then the inductor should be specified with a saturation current limit of > 1.25A. There is no need to specify the saturation or peak current of the inductor at the 2.9A typical switch current limit. Because of the operating frequency of the LM2738, ferrite based inductors are preferred to minimize core losses. This presents little restriction since the variety of ferrite-based inductors is huge. Lastly, inductors with lower series resistance (R_{DCR}) will provide better operating efficiency. For recommended inductors see Example Circuits.

INPUT CAPACITOR

An input capacitor is necessary to ensure that V_{IN} does not drop excessively during switching transients. The primary specifications of the input capacitor are capacitance, voltage, RMS current rating, and ESL (Equivalent Series Inductance). The recommended input capacitance is 10 μ F. The input voltage rating is specifically stated by the capacitor manufacturer. Make sure to check any recommended deratings and also verify if there is any significant change in capacitance at the operating input voltage and the operating temperature. The input capacitor maximum RMS input current rating (I_{RMS-IN}) must be greater than:

$$I_{RMS_IN} \sqrt{D \left[I_{OUT}^2 (1-D) + \frac{\Delta i^2}{3} \right]}$$

Neglecting inductor ripple simplifies the above equation to:

$$I_{RMS_IN} = I_{OUT} \times \sqrt{D(1-D)}$$

It can be shown from the above equation that maximum RMS capacitor current occurs when $D = 0.5$. Always calculate the RMS at the point where the duty cycle D is closest to 0.5. The ESL of an input capacitor is usually determined by the effective cross sectional area of the current path. A large leaded capacitor will have high ESL and a 0805 ceramic chip capacitor will have very low ESL. At the operating frequencies of the LM2738, leaded capacitors may have an ESL so large that the resulting impedance ($2\pi fL$) will be higher than that required to provide stable operation. As a result, surface mount capacitors are strongly recommended.

Sanyo POSCAP, Tantalum or Niobium, Panasonic SP, and multilayer ceramic capacitors (MLCC) are all good choices for both input and output capacitors and have very low ESL. For MLCCs it is recommended to use X7R or X5R type capacitors due to their tolerance and temperature characteristics. Consult capacitor manufacturer datasheets to see how rated capacitance varies over operating conditions.

OUTPUT CAPACITOR

The output capacitor is selected based upon the desired output ripple and transient response. The initial current of a load transient is provided mainly by the output capacitor. The output ripple of the converter is:

$$\Delta V_{OUT} = \Delta I_L \left(R_{ESR} + \frac{1}{8 \times F_{SW} \times C_{OUT}} \right)$$

When using MLCCs, the ESR is typically so low that the capacitive ripple may dominate. When this occurs, the output

ripple will be approximately sinusoidal and 90° phase shifted from the switching action. Given the availability and quality of MLCCs and the expected output voltage of designs using the LM2738, there is really no need to review any other capacitor technologies. Another benefit of ceramic capacitors is their ability to bypass high frequency noise. A certain amount of switching edge noise will couple through parasitic capacitances in the inductor to the output. A ceramic capacitor will bypass this noise while a tantalum will not. Since the output capacitor is one of the two external components that control the stability of the regulator control loop, most applications will require a minimum of 22 μ F of output capacitance. Capacitance, in general, is often increased when operating at lower duty cycles. Refer to the circuit examples at the end of the datasheet for suggested output capacitances of common applications. Like the input capacitor, recommended multilayer ceramic capacitors are X7R or X5R types.

CATCH DIODE

The catch diode (D1) conducts during the switch off-time. A Schottky diode is recommended for its fast switching times and low forward voltage drop. The catch diode should be chosen so that its current rating is greater than:

$$I_{D1} = I_{OUT} \times (1-D)$$

The reverse breakdown rating of the diode must be at least the maximum input voltage plus appropriate margin. To improve efficiency, choose a Schottky diode with a low forward voltage drop.

OUTPUT VOLTAGE

The output voltage is set using the following equation where R2 is connected between the FB pin and GND, and R1 is connected between V_O and the FB pin. A good value for R2 is 10k. When designing a unity gain converter ($V_O = 0.8V$), R1 should be between 0 Ω and 100 Ω , and R2 should not be loaded.

$$R1 = \left(\frac{V_O}{V_{REF}} - 1 \right) \times R2$$

$$V_{REF} = 0.80V$$

PCB LAYOUT CONSIDERATIONS

When planning layout there are a few things to consider when trying to achieve a clean, regulated output. The most important consideration is the close coupling of the GND connections of the input capacitor and the catch diode D1. These ground ends should be close to one another and be connected to the GND plane with at least two through-holes. Place these components as close to the IC as possible. Next in importance is the location of the GND connection of the output capacitor, which should be near the GND connections of C_{IN} and D1. There should be a continuous ground plane on the bottom layer of a two-layer board except under the switching node island. The FB pin is a high impedance node and care should be taken to make the FB trace short to avoid noise pickup and inaccurate regulation. The feedback resistors should be placed as close as possible to the IC, with the GND of R1 placed as close as possible to the GND of the IC. The V_{OUT} trace to R2 should be routed away from the inductor and any other traces that are switching. High AC currents flow through the V_{IN} , SW and V_{OUT} traces, so they should be as short and wide as possible. However, making the traces wide increases radiated noise, so the designer must make this trade-off. Radiated noise can be decreased by choosing a

shielded inductor. The remaining components should also be placed as close as possible to the IC. Please see Application Note AN-1229 for further considerations and the LM2738 demo board as an example of a four-layer layout.

RECOMMENDED OPERATING AREA DUE TO MINIMUM ON TIME

The LM2738 operates over a wide range of conditions, which is limited by the ON time of the device. A graph is provided to show the recommended operating area for the "X" at the full load (1.5A) and at 25°C ambient. The "Y" version of the LM2738 operates at a lower frequency and therefore operates over the entire range of operating voltages.

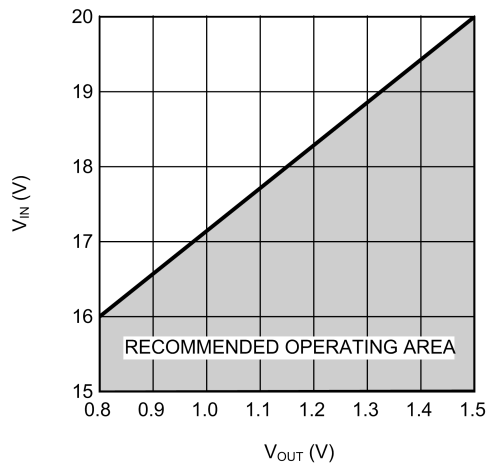

30049187

FIGURE 7. LM2738X - 1.6MHz (25°C, LOAD=1.5A)

Calculating Efficiency, and Junction Temperature

The complete LM2738 DC/DC converter efficiency can be calculated in the following manner.

$$\eta = \frac{P_{OUT}}{P_{IN}}$$

Or

$$\eta = \frac{P_{OUT}}{P_{OUT} + P_{LOSS}}$$

Calculations for determining the most significant power losses are shown below. Other losses totaling less than 2% are not discussed.

Power loss (P_{LOSS}) is the sum of two basic types of losses in the converter: switching and conduction. Conduction losses usually dominate at higher output loads, whereas switching losses remain relatively fixed and dominate at lower output loads. The first step in determining the losses is to calculate the duty cycle (D):

$$D = \frac{V_{OUT} + V_D}{V_{IN} + V_D - V_{SW}}$$

V_{SW} is the voltage drop across the internal NFET when it is on, and is equal to:

$$V_{SW} = I_{OUT} \times R_{DS(ON)}$$

V_D is the forward voltage drop across the Schottky catch diode. It can be obtained from the diode manufacturer's Electrical Characteristics section. If the voltage drop across the inductor (V_{DCR}) is accounted for, the equation becomes:

$$D = \frac{V_{OUT} + V_D + V_{DCR}}{V_{IN} + V_D + V_{DCR} - V_{SW}}$$

The conduction losses in the free-wheeling Schottky diode are calculated as follows:

$$P_{DIODE} = V_D \times I_{OUT} \times (1-D)$$

Often this is the single most significant power loss in the circuit. Care should be taken to choose a Schottky diode that has a low forward voltage drop.

Another significant external power loss is the conduction loss in the output inductor. The equation can be simplified to:

$$P_{IND} = I_{OUT}^2 \times R_{DCR}$$

The LM2738 conduction loss is mainly associated with the internal NFET switch:

$$P_{COND} = (I_{OUT}^2 \times D) \left(1 + \frac{1}{3} \times \left(\frac{\Delta i_L}{I_{OUT}} \right)^2 \right) R_{DS(ON)}$$

If the inductor ripple current is fairly small, the conduction losses can be simplified to:

$$P_{COND} = I_{OUT}^2 \times R_{DS(ON)} \times D$$

Switching losses are also associated with the internal NFET switch. They occur during the switch on and off transition periods, where voltages and currents overlap resulting in power loss. The simplest means to determine this loss is to empirically measure the rise and fall times (10% to 90%) of the switch at the switch node.

Switching Power Loss is calculated as follows:

$$P_{SWR} = 1/2(V_{IN} \times I_{OUT} \times F_{SW} \times T_{RISE})$$

$$P_{SWF} = 1/2(V_{IN} \times I_{OUT} \times F_{SW} \times T_{FALL})$$

$$P_{SW} = P_{SWR} + P_{SWF}$$

Another loss is the power required for operation of the internal circuitry:

$$P_Q = I_Q \times V_{IN}$$

I_Q is the quiescent operating current, and is typically around 1.9mA for the 0.55MHz frequency option.

Typical Application power losses are:

Power Loss Tabulation

V_{IN}	12.0V		
V_{OUT}	3.3V	P_{OUT}	4.125W
I_{OUT}	1.25A		
V_D	0.34V	P_{DIODE}	317mW
F_{SW}	550kHz		
I_Q	1.9mA	P_Q	22.8mW
T_{RISE}	8nS	P_{SWR}	33mW
T_{FALL}	8nS	P_{SWF}	33mW
$R_{DS(ON)}$	275m Ω	P_{COND}	118mW
IND_{DCR}	70m Ω	P_{IND}	110mW
D	0.275	P_{LOSS}	634mW
η	86.7%	$P_{INTERNAL}$	207mW

$$\Sigma P_{COND} + P_{SW} + P_{DIODE} + P_{IND} + P_Q = P_{LOSS}$$

$$\Sigma P_{COND} + P_{SWF} + P_{SWR} + P_Q = P_{INTERNAL}$$

$$P_{INTERNAL} = 207mW$$

Thermal Definitions

T_J = Chip junction temperature

T_A = Ambient temperature

$R_{\theta JC}$ = Thermal resistance from chip junction to device case

$R_{\theta JA}$ = Thermal resistance from chip junction to ambient air

Heat in the LM2738 due to internal power dissipation is removed through conduction and/or convection.

Conduction: Heat transfer occurs through cross sectional areas of material. Depending on the material, the transfer of heat can be considered to have poor to good thermal conductivity properties (insulator vs. conductor).

Heat Transfer goes as:

Silicon \rightarrow package \rightarrow lead frame \rightarrow PCB

Convection: Heat transfer is by means of airflow. This could be from a fan or natural convection. Natural convection occurs when air currents rise from the hot device to cooler air.

Thermal impedance is defined as:

$$R_{\theta} = \frac{\Delta T}{\text{Power}}$$

Thermal impedance from the silicon junction to the ambient air is defined as:

$$R_{\theta JA} = \frac{T_J - T_A}{\text{Power}}$$

The PCB size, weight of copper used to route traces and ground plane, and number of layers within the PCB can greatly effect $R_{\theta JA}$. The type and number of thermal vias can also make a large difference in the thermal impedance. Thermal vias are necessary in most applications. They conduct heat from the surface of the PCB to the ground plane. Four to six thermal vias should be placed under the exposed pad to the ground plane if the LLP package is used.

Thermal impedance also depends on the thermal properties due to the application's operating conditions (V_{in} , V_o , I_o etc), and the surrounding circuitry.

Silicon Junction Temperature Determination Method 1:

To accurately measure the silicon temperature for a given application, two methods can be used. The first method requires the user to know the thermal impedance of the silicon junction to top case temperature.

Some clarification needs to be made before we go any further.

$R_{\theta JC}$ is the thermal impedance from all six sides of an IC package to silicon junction.

$R_{\phi JC}$ is the thermal impedance from top case to the silicon junction.

In this data sheet we will use $R_{\phi JC}$ so that it allows the user to measure top case temperature with a small thermocouple attached to the top case.

$R_{\phi JC}$ is approximately 30°C/Watt for the 8-pin LLP package with the exposed pad. Knowing the internal dissipation from the efficiency calculation given previously, and the case temperature, which can be empirically measured on the bench we have:

$$R_{\phi JC} = \frac{T_J - T_C}{\text{Power}}$$

Therefore:

$$T_J = (R_{\phi JC} \times P_{\text{LOSS}}) + T_C$$

From the previous example:

$$T_J = (R_{\phi JC} \times P_{\text{INTERNAL}}) + T_C$$

$$T_J = 30^{\circ}\text{C/W} \times 0.207\text{W} + T_C$$

The second method can give a very accurate silicon junction temperature.

The first step is to determine $R_{\theta JA}$ of the application. The LM2738 has over-temperature protection circuitry. When the silicon temperature reaches 165°C, the device stops switching. The protection circuitry has a hysteresis of about 15°C. Once the silicon temperature has decreased to approximately 150°C, the device will start to switch again. Knowing this, the $R_{\theta JA}$ for any application can be characterized during the early stages of the design one may calculate the $R_{\theta JA}$ by placing the PCB circuit into a thermal chamber. Raise the ambient temperature in the given working application until the circuit

enters thermal shutdown. If the SW-pin is monitored, it will be obvious when the internal NFET stops switching, indicating a junction temperature of 165°C. Knowing the internal power dissipation from the above methods, the junction temperature, and the ambient temperature $R_{\theta JA}$ can be determined.

$$R_{\theta JA} = \frac{165^{\circ} - T_a}{P_{\text{INTERNAL}}}$$

Once this is determined, the maximum ambient temperature allowed for a desired junction temperature can be found.

An example of calculating $R_{\theta JA}$ for an application using the National Semiconductor LM2738 LLP demonstration board is shown below.

The four layer PCB is constructed using FR4 with ½ oz copper traces. The copper ground plane is on the bottom layer. The ground plane is accessed by two vias. The board measures 3.0cm x 3.0cm. It was placed in an oven with no forced airflow. The ambient temperature was raised to 144°C, and at that temperature, the device went into thermal shutdown.

From the previous example:

$$P_{\text{INTERNAL}} = 207\text{mW}$$

$$R_{\theta JA} = \frac{165^{\circ}\text{C} - 144^{\circ}\text{C}}{207\text{ mW}} = 102^{\circ}\text{C/W}$$

If the junction temperature was to be kept below 125°C, then the ambient temperature could not go above 109°C

$$T_J - (R_{\theta JA} \times P_{\text{LOSS}}) = T_A$$

$$125^{\circ}\text{C} - (102^{\circ}\text{C/W} \times 207\text{mW}) = 104^{\circ}\text{C}$$

LLP Package

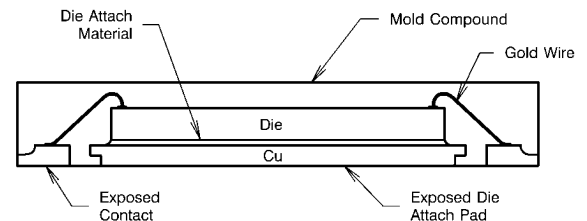

30049174

FIGURE 8. Internal LLP Connection

For certain high power applications, the PCB land may be modified to a "dog bone" shape (see [Figure 9](#)). By increasing the size of ground plane, and adding thermal vias, the $R_{\theta JA}$ for the application can be reduced.

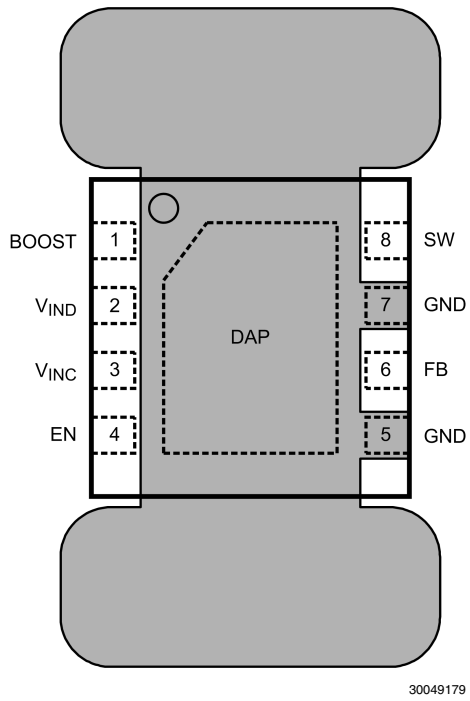
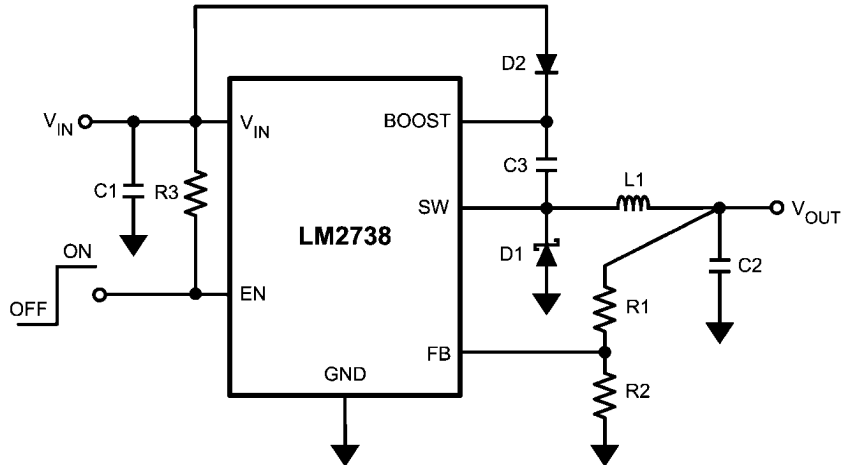

FIGURE 9. 8-Lead LLP PCB Dog Bone Layout

LM2738X Circuit Example 1



30049142

FIGURE 10. LM2738X (1.6MHz)
 V_{BOOST} Derived from V_{IN}
 5V to 1.5V/1.5A

Bill of Materials for *Figure 10*

Part ID	Part Value	Part Number	Manufacturer
U1	1.5A Buck Regulator	LM2738X	National Semiconductor
C1, Input Cap	10µF, 6.3V, X5R	C3216X5ROJ106M	TDK
C2, Output Cap	22µF, 6.3V, X5R	C3216X5ROJ226M	TDK
C3, Boost Cap	0.1µF, 16V, X7R	C1005X7R1C104K	TDK
D1, Catch Diode	0.34V _F Schottky 1.5A, 30V	CRS08	Toshiba
D2, Boost Diode	1V _F @ 100mA Diode	BAT54WS	Diodes, Inc.
L1	2.2µH, 1.9A,	MSS5131-222ML	Coilcraft
R1	8.87kΩ, 1%	CRCW06038871F	Vishay
R2	10.2kΩ, 1%	CRCW06031022F	Vishay
R3	100kΩ, 1%	CRCW06031003F	Vishay

LM2738X Circuit Example 2

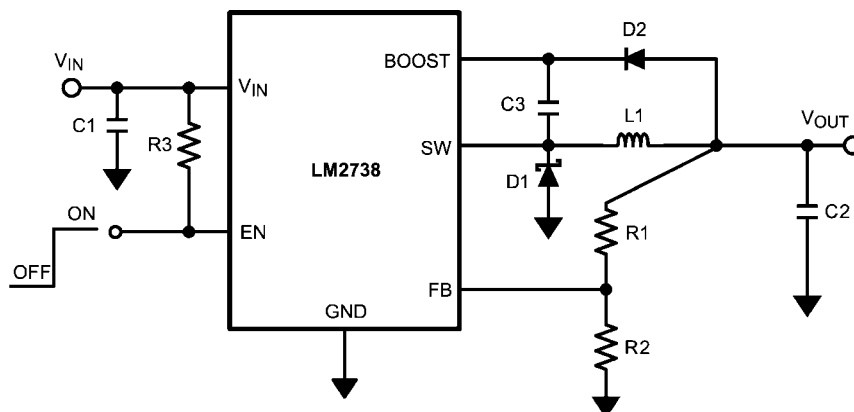

30049193

FIGURE 11. LM2738X (1.6MHz)
 V_{BOOST} Derived from V_{OUT}
 12V to 3.3V/1.5A

Bill of Materials for *Figure 11*

Part ID	Part Value	Part Number	Manufacturer
U1	1.5A Buck Regulator	NSC	LM2738X
C1, Input Cap	10µF, 25V, X7R	C3225X7R1E106M	TDK
C2, Output Cap	33µF, 6.3V, X5R	C3216X5ROJ336M	TDK
C3, Boost Cap	0.1µF, 16V, X7R	C1005X7R1C104K	TDK
D1, Catch Diode	0.34V _F Schottky 1.5A, 30V	CRS08	Toshiba
D2, Boost Diode	1V _F @ 100mA Diode	BAT54WS	Diodes, Inc.
L1	5µH, 2.9A	MSS7341- 502NL	Coilcraft
R1	31.6kΩ, 1%	CRCW06033162F	Vishay
R2	10kΩ, 1%	CRCW06031002F	Vishay
R3	100kΩ, 1%	CRCW06031003F	Vishay

LM2738X Circuit Example 4

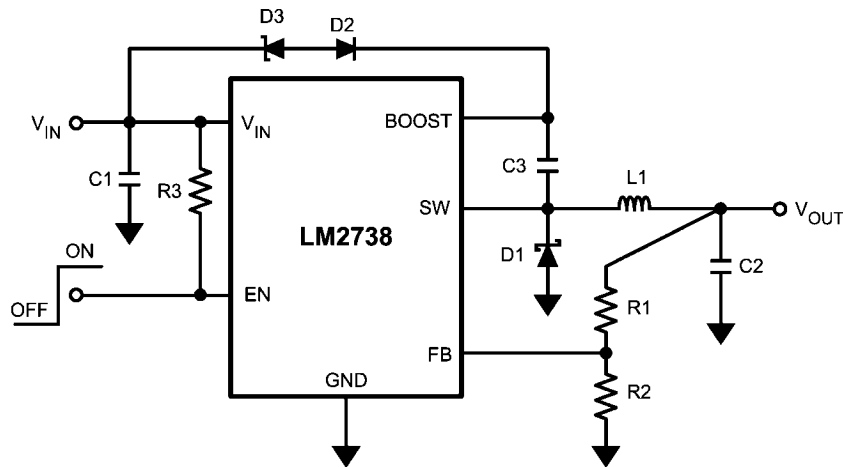

30049149

FIGURE 13. LM2738X (1.6MHz)
 V_{BOOST} Derived from Series Zener Diode (V_{IN})
 15V to 1.5V/1.5A

Bill of Materials for *Figure 13*

Part ID	Part Value	Part Number	Manufacturer
U1	1.5A Buck Regulator	LM2738X	National Semiconductor
C1, Input Cap	10µF, 25V, X7R	C3225X7R1E106M	TDK
C2, Output Cap	47µF, 6.3V, X5R	C3216X5ROJ476M	TDK
C3, Boost Cap	0.1µF, 16V, X7R	C1005X7R1C104K	TDK
D1, Catch Diode	0.34V _F Schottky 1.5A, 30V	CRS08	Toshiba
D2, Boost Diode	1V _F @ 100mA Diode	BAT54WS	Diodes, Inc.
D3, Zener Diode	11V 350Mw SOT-23	BZX84C11T	Diodes, Inc.
L1	3.3µH, 3.5A	MSS7341-332NL	Coilcraft
R1	8.87kΩ, 1%	CRCW06038871F	Vishay
R2	10.2kΩ, 1%	CRCW06031022F	Vishay
R3	100kΩ, 1%	CRCW06031003F	Vishay

LM2738X Circuit Example 5

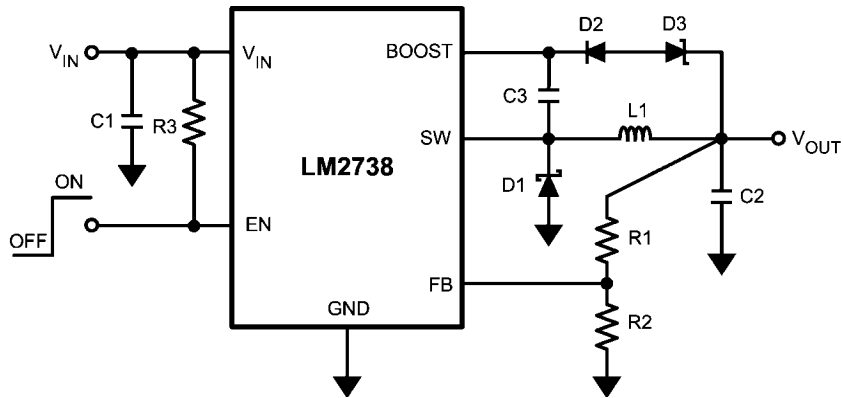

30049150

FIGURE 14. LM2738X (1.6MHz)
 V_{BOOST} Derived from Series Zener Diode (V_{OUT})
 15V to 9V/1.5A

Bill of Materials for *Figure 14*

Part ID	Part Value	Part Number	Manufacturer
U1	1.5A Buck Regulator	LM2738X	National Semiconductor
C1, Input Cap	10µF, 25V, X7R	C3225X7R1E106M	TDK
C2, Output Cap	22µF, 16V, X5R	C3216X5R1C226M	TDK
C3, Boost Cap	0.1µF, 16V, X7R	C1005X7R1C104K	TDK
D1, Catch Diode	0.34V _F Schottky 1.5A, 30V	CRS08	Toshiba
D2, Boost Diode	1V _F @ 100mA Diode	BAT54WS	Diodes, Inc.
D3, Zener Diode	4.3V 350mw SOT-23	BZX84C4V3	Diodes, Inc.
L1	6.2µH, 2.5A	MSS7341-622NL	Coilcraft
R1	102kΩ, 1%	CRCW06031023F	Vishay
R2	10.2kΩ, 1%	CRCW06031022F	Vishay
R3	100kΩ, 1%	CRCW06031003F	Vishay

LM2738Y Circuit Example 6

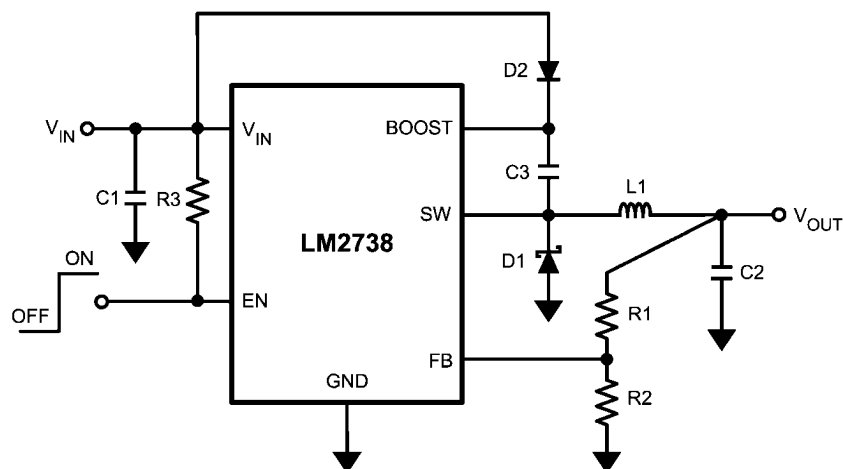

30049142

FIGURE 15. LM2738Y (550kHz)
 V_{BOOST} Derived from V_{IN}
 5V to 1.5V/1.5A

Bill of Materials for *Figure 15*

Part ID	Part Value	Part Number	Manufacturer
U1	1.5A Buck Regulator	LM2738Y	National Semiconductor
C1, Input Cap	10µF, 6.3V, X5R	C3216X5ROJ106M	TDK
C2, Output Cap	47µF, 6.3V, X5R	C3216X5ROJ476M	TDK
C3, Boost Cap	0.1µF, 16V, X7R	C1005X7R1C104K	TDK
D1, Catch Diode	0.34V _F Schottky 1.5A, 30V	CRS08	Toshiba
D2, Boost Diode	1V _F @ 100mA Diode	BAT54WS	Diodes, Inc.
L1	6.2µH, 2.5A,	MSS7341-622NL	Coilcraft
R1	8.87kΩ, 1%	CRCW06038871F	Vishay
R2	10.2kΩ, 1%	CRCW06031022F	Vishay
R3	100kΩ, 1%	CRCW06031003F	Vishay

LM2738Y Circuit Example 7

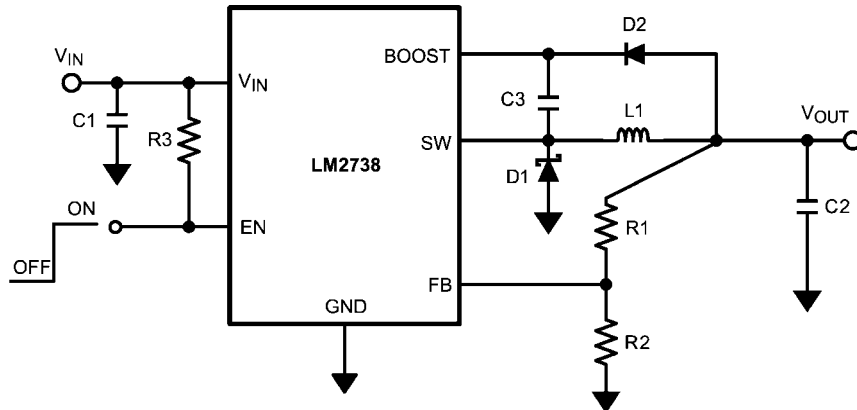

30049193

FIGURE 16. LM2738Y (550kHz)
 V_{BOOST} Derived from V_{OUT}
 12V to 3.3V/1.5A

Bill of Materials for *Figure 16*

Part ID	Part Value	Part Number	Manufacturer
U1	1.5A Buck Regulator	LM2738Y	National Semiconductor
C1, Input Cap	10 μ F, 25V, X7R	C3225X7R1E106M	TDK
C2, Output Cap	47 μ F, 6.3V, X5R	C3216X5ROJ476M	TDK
C3, Boost Cap	0.1 μ F, 16V, X7R	C1005X7R1C104K	TDK
D1, Catch Diode	0.34V _F Schottky 1.5A, 30V	CRS08	Toshiba
D2, Boost Diode	1V _F @ 100mA Diode	BAT54WS	Vishay
L1	12 μ H, 1.7A,	MSS7341-123NL	Coilcraft
R1	31.6k Ω , 1%	CRCW06033162F	Vishay
R2	10.0 k Ω , 1%	CRCW06031002F	Vishay
R3	100k Ω , 1%	CRCW06031003F	Vishay

LM2738Y Circuit Example 8

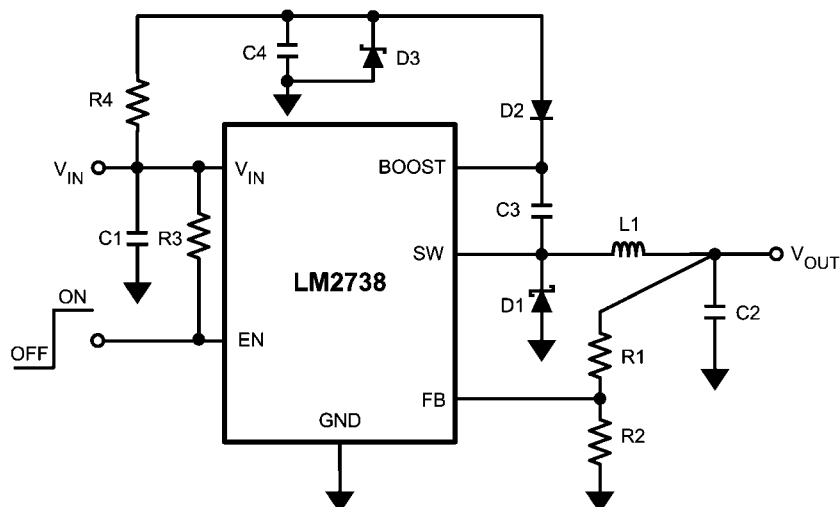

30049144

FIGURE 17. LM2738Y (550kHz)
 V_{BOOST} Derived from V_{SHUNT}
 18V to 1.5V/1.5A

Bill of Materials for *Figure 17*

Part ID	Part Value	Part Number	Manufacturer
U1	1.5A Buck Regulator	LM2738Y	National Semiconductor
C1, Input Cap	10 μ F, 25V, X7R	C3225X7R1E106M	TDK
C2, Output Cap	(47 μ F, 6.3V, X5R) x 2 = 94 μ F	C3216X5ROJ476M	TDK
C3, Boost Cap	0.1 μ F, 16V, X7R	C1005X7R1C104K	TDK
C4, Shunt Cap	0.1 μ F, 6.3V, X5R	C1005X5R0J104K	TDK
D1, Catch Diode	0.34V _F Schottky 1.5A, 30V	CRS08	Toshiba
D2, Boost Diode	1V _F @ 100mA Diode	BAT54WS	Diodes, Inc.
D3, Zener Diode	5.1V 250Mw SOT-23	BZX84C5V1	Vishay
L1	8.7 μ H, 2.2A	MSS7341-872NL	Coilcraft
R1	8.87k Ω , 1%	CRCW06038871F	Vishay
R2	10.2k Ω , 1%	CRCW06031022F	Vishay
R3	100k Ω , 1%	CRCW06031003F	Vishay
R4	4.12k Ω , 1%	CRCW06034121F	Vishay

LM2738Y Circuit Example 9

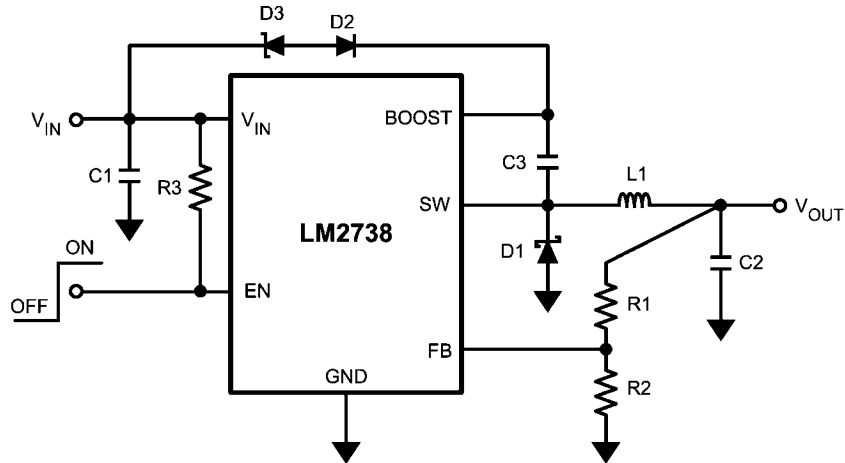

30049149

FIGURE 18. LM2738Y (550kHz)
 V_{BOOST} Derived from Series Zener Diode (V_{IN})
 15V to 1.5V/1.5A

Bill of Materials for *Figure 18*

Part ID	Part Value	Part Number	Manufacturer
U1	1.5A Buck Regulator	LM2738Y	National Semiconductor
C1, Input Cap	10µF, 25V, X7R	C3225X7R1E106M	TDK
C2, Output Cap	(47µF, 6.3V, X5R) x 2 = 94µF	C3216X5ROJ476M	TDK
C3, Boost Cap	0.1µF, 16V, X7R	C1005X7R1C104K	TDK
D1, Catch Diode	0.34V _F Schottky 1.5A, 30V	CRS08	Toshiba
D2, Boost Diode	1V _F @ 100mA Diode	BAT54WS	Diodes, Inc.
D3, Zener Diode	11V 350Mw SOT-23	BZX84C11T	Diodes, Inc.
L1	8.7µH, 2.2A	MSS7341-872NL	Coilcraft
R1	8.87kΩ, 1%	CRCW06038871F	Vishay
R2	10.2kΩ, 1%	CRCW06031022F	Vishay
R3	100kΩ, 1%	CRCW06031003F	Vishay

LM2738Y Circuit Example 10

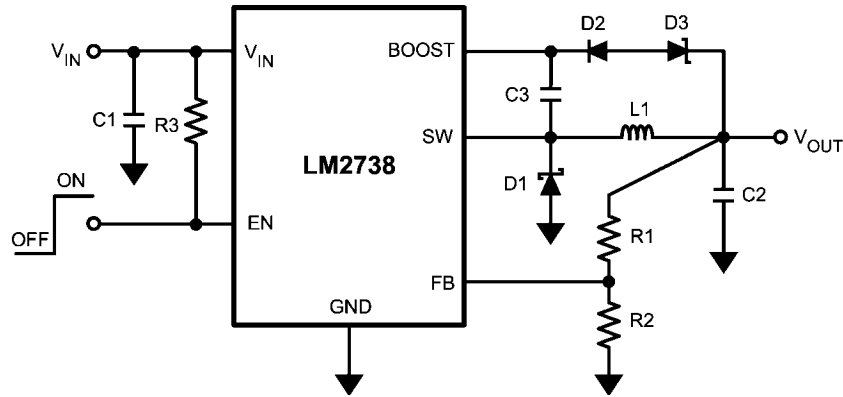

30049150

FIGURE 19. LM2738Y (550kHz)
 V_{BOOST} Derived from Series Zener Diode (V_{OUT})
 15V to 9V/1.5A

Bill of Materials for *Figure 19*

Part ID	Part Value	Part Number	Manufacturer
U1	1.5A Buck Regulator	LM2738Y	National Semiconductor
C1, Input Cap	10µF, 25V, X7R	C3225X7R1E106M	TDK
C2, Output Cap	22µF, 16V, X5R	C3216X5R1C226M	TDK
C3, Boost Cap	0.1µF, 16V, X7R	C1005X7R1C104K	TDK
D1, Catch Diode	0.34V _F Schottky 1.5A, 30V	CRS08	Toshiba
D2, Boost Diode	1V _F @ 100mA Diode	BAT54WS	Diodes, Inc.
D3, Zener Diode	4.3V 350mw SOT-23	BZX84C4V3	Diodes, Inc.
L1	15µH, 2.1A	SLF7055T150M2R1-3PF	TDK
R1	102kΩ, 1%	CRCW06031023F	Vishay
R2	10.2kΩ, 1%	CRCW06031022F	Vishay
R3	100kΩ, 1%	CRCW06031003F	Vishay

Physical Dimensions inches (millimeters) unless otherwise noted

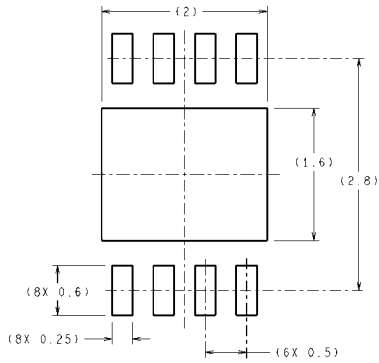

RECOMMENDED LAND PATTERN

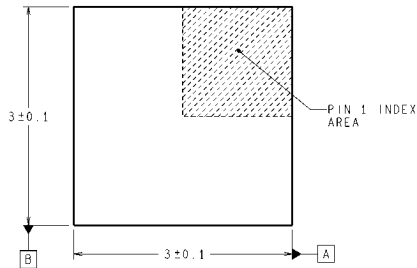

DIMENSIONS ARE IN MILLIMETERS
DIMENSIONS IN () FOR REFERENCE ONLY

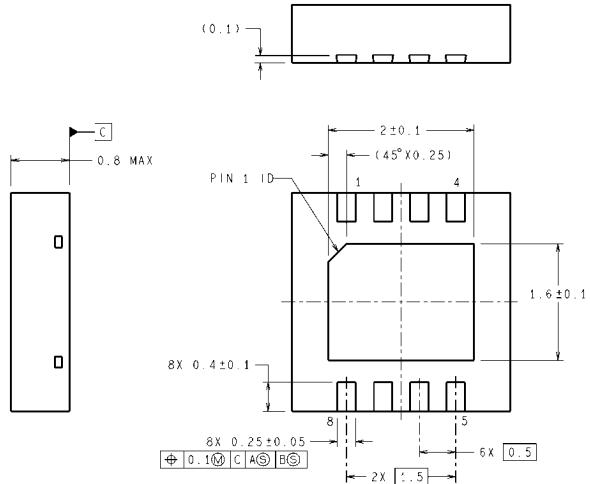

SDA08A (Rev A)

8-Lead LLP Package
NS Package Number SDA08A

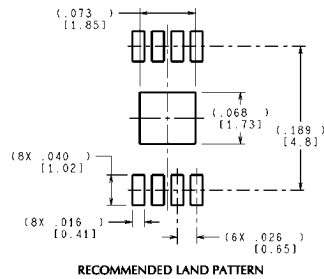
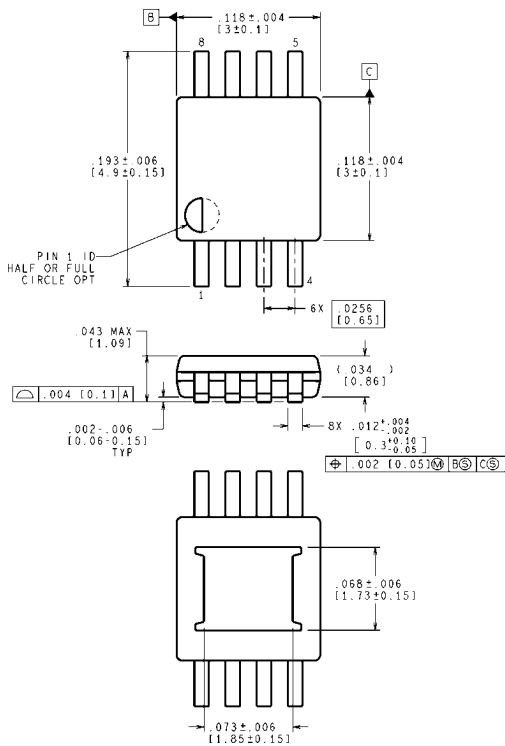

RECOMMENDED LAND PATTERN

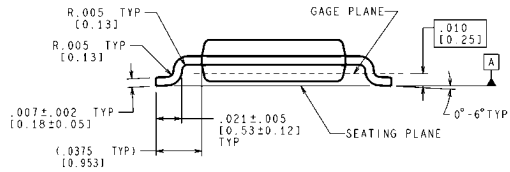

CONTROLLING DIMENSION IS INCH
VALUES IN [] ARE MILLIMETERS

8-Lead eMSOP Package
NS Package Number MUY08A

MUY08A (Rev A)

Notes

LM2738

Notes

For more National Semiconductor product information and proven design tools, visit the following Web sites at:
www.national.com

Products		Design Support	
Amplifiers	www.national.com/amplifiers	WEBENCH® Tools	www.national.com/webench
Audio	www.national.com/audio	App Notes	www.national.com/appnotes
Clock and Timing	www.national.com/timing	Reference Designs	www.national.com/refdesigns
Data Converters	www.national.com/adc	Samples	www.national.com/samples
Interface	www.national.com/interface	Eval Boards	www.national.com/evalboards
LVDS	www.national.com/lvds	Packaging	www.national.com/packaging
Power Management	www.national.com/power	Green Compliance	www.national.com/quality/green
Switching Regulators	www.national.com/switchers	Distributors	www.national.com/contacts
LDOs	www.national.com/ldo	Quality and Reliability	www.national.com/quality
LED Lighting	www.national.com/led	Feedback/Support	www.national.com/feedback
Voltage References	www.national.com/vref	Design Made Easy	www.national.com/easy
PowerWise® Solutions	www.national.com/powerwise	Applications & Markets	www.national.com/solutions
Serial Digital Interface (SDI)	www.national.com/sdi	Mil/Aero	www.national.com/milaero
Temperature Sensors	www.national.com/tempensors	SolarMagic™	www.national.com/solarmagic
PLL/VCO	www.national.com/wireless	PowerWise® Design University	www.national.com/training

THE CONTENTS OF THIS DOCUMENT ARE PROVIDED IN CONNECTION WITH NATIONAL SEMICONDUCTOR CORPORATION ("NATIONAL") PRODUCTS. NATIONAL MAKES NO REPRESENTATIONS OR WARRANTIES WITH RESPECT TO THE ACCURACY OR COMPLETENESS OF THE CONTENTS OF THIS PUBLICATION AND RESERVES THE RIGHT TO MAKE CHANGES TO SPECIFICATIONS AND PRODUCT DESCRIPTIONS AT ANY TIME WITHOUT NOTICE. NO LICENSE, WHETHER EXPRESS, IMPLIED, ARISING BY ESTOPPEL OR OTHERWISE, TO ANY INTELLECTUAL PROPERTY RIGHTS IS GRANTED BY THIS DOCUMENT.

TESTING AND OTHER QUALITY CONTROLS ARE USED TO THE EXTENT NATIONAL DEEMS NECESSARY TO SUPPORT NATIONAL'S PRODUCT WARRANTY. EXCEPT WHERE MANDATED BY GOVERNMENT REQUIREMENTS, TESTING OF ALL PARAMETERS OF EACH PRODUCT IS NOT NECESSARILY PERFORMED. NATIONAL ASSUMES NO LIABILITY FOR APPLICATIONS ASSISTANCE OR BUYER PRODUCT DESIGN. BUYERS ARE RESPONSIBLE FOR THEIR PRODUCTS AND APPLICATIONS USING NATIONAL COMPONENTS. PRIOR TO USING OR DISTRIBUTING ANY PRODUCTS THAT INCLUDE NATIONAL COMPONENTS, BUYERS SHOULD PROVIDE ADEQUATE DESIGN, TESTING AND OPERATING SAFEGUARDS.

EXCEPT AS PROVIDED IN NATIONAL'S TERMS AND CONDITIONS OF SALE FOR SUCH PRODUCTS, NATIONAL ASSUMES NO LIABILITY WHATSOEVER, AND NATIONAL DISCLAIMS ANY EXPRESS OR IMPLIED WARRANTY RELATING TO THE SALE AND/OR USE OF NATIONAL PRODUCTS INCLUDING LIABILITY OR WARRANTIES RELATING TO FITNESS FOR A PARTICULAR PURPOSE, MERCHANTABILITY, OR INFRINGEMENT OF ANY PATENT, COPYRIGHT OR OTHER INTELLECTUAL PROPERTY RIGHT.

LIFE SUPPORT POLICY

NATIONAL'S PRODUCTS ARE NOT AUTHORIZED FOR USE AS CRITICAL COMPONENTS IN LIFE SUPPORT DEVICES OR SYSTEMS WITHOUT THE EXPRESS PRIOR WRITTEN APPROVAL OF THE CHIEF EXECUTIVE OFFICER AND GENERAL COUNSEL OF NATIONAL SEMICONDUCTOR CORPORATION. As used herein:

Life support devices or systems are devices which (a) are intended for surgical implant into the body, or (b) support or sustain life and whose failure to perform when properly used in accordance with instructions for use provided in the labeling can be reasonably expected to result in a significant injury to the user. A critical component is any component in a life support device or system whose failure to perform can be reasonably expected to cause the failure of the life support device or system or to affect its safety or effectiveness.

National Semiconductor and the National Semiconductor logo are registered trademarks of National Semiconductor Corporation. All other brand or product names may be trademarks or registered trademarks of their respective holders.

Copyright© 2011 National Semiconductor Corporation

For the most current product information visit us at www.national.com



National Semiconductor Americas Technical Support Center
 Email: support@nsc.com
 Tel: 1-800-272-9959

National Semiconductor Europe Technical Support Center
 Email: europe.support@nsc.com

National Semiconductor Asia Pacific Technical Support Center
 Email: ap.support@nsc.com

National Semiconductor Japan Technical Support Center
 Email: jpn.feedback@nsc.com

IMPORTANT NOTICE

Texas Instruments Incorporated and its subsidiaries (TI) reserve the right to make corrections, modifications, enhancements, improvements, and other changes to its products and services at any time and to discontinue any product or service without notice. Customers should obtain the latest relevant information before placing orders and should verify that such information is current and complete. All products are sold subject to TI's terms and conditions of sale supplied at the time of order acknowledgment.

TI warrants performance of its hardware products to the specifications applicable at the time of sale in accordance with TI's standard warranty. Testing and other quality control techniques are used to the extent TI deems necessary to support this warranty. Except where mandated by government requirements, testing of all parameters of each product is not necessarily performed.

TI assumes no liability for applications assistance or customer product design. Customers are responsible for their products and applications using TI components. To minimize the risks associated with customer products and applications, customers should provide adequate design and operating safeguards.

TI does not warrant or represent that any license, either express or implied, is granted under any TI patent right, copyright, mask work right, or other TI intellectual property right relating to any combination, machine, or process in which TI products or services are used. Information published by TI regarding third-party products or services does not constitute a license from TI to use such products or services or a warranty or endorsement thereof. Use of such information may require a license from a third party under the patents or other intellectual property of the third party, or a license from TI under the patents or other intellectual property of TI.

Reproduction of TI information in TI data books or data sheets is permissible only if reproduction is without alteration and is accompanied by all associated warranties, conditions, limitations, and notices. Reproduction of this information with alteration is an unfair and deceptive business practice. TI is not responsible or liable for such altered documentation. Information of third parties may be subject to additional restrictions.

Resale of TI products or services with statements different from or beyond the parameters stated by TI for that product or service voids all express and any implied warranties for the associated TI product or service and is an unfair and deceptive business practice. TI is not responsible or liable for any such statements.

TI products are not authorized for use in safety-critical applications (such as life support) where a failure of the TI product would reasonably be expected to cause severe personal injury or death, unless officers of the parties have executed an agreement specifically governing such use. Buyers represent that they have all necessary expertise in the safety and regulatory ramifications of their applications, and acknowledge and agree that they are solely responsible for all legal, regulatory and safety-related requirements concerning their products and any use of TI products in such safety-critical applications, notwithstanding any applications-related information or support that may be provided by TI. Further, Buyers must fully indemnify TI and its representatives against any damages arising out of the use of TI products in such safety-critical applications.

TI products are neither designed nor intended for use in military/aerospace applications or environments unless the TI products are specifically designated by TI as military-grade or "enhanced plastic." Only products designated by TI as military-grade meet military specifications. Buyers acknowledge and agree that any such use of TI products which TI has not designated as military-grade is solely at the Buyer's risk, and that they are solely responsible for compliance with all legal and regulatory requirements in connection with such use.

TI products are neither designed nor intended for use in automotive applications or environments unless the specific TI products are designated by TI as compliant with ISO/TS 16949 requirements. Buyers acknowledge and agree that, if they use any non-designated products in automotive applications, TI will not be responsible for any failure to meet such requirements.

Following are URLs where you can obtain information on other Texas Instruments products and application solutions:

Products

Audio	www.ti.com/audio
Amplifiers	amplifier.ti.com
Data Converters	dataconverter.ti.com
DLP® Products	www.dlp.com
DSP	dsp.ti.com
Clocks and Timers	www.ti.com/clocks
Interface	interface.ti.com
Logic	logic.ti.com
Power Mgmt	power.ti.com
Microcontrollers	microcontroller.ti.com
RFID	www.ti-rfid.com
OMAP Mobile Processors	www.ti.com/omap
Wireless Connectivity	www.ti.com/wirelessconnectivity

Applications

Communications and Telecom	www.ti.com/communications
Computers and Peripherals	www.ti.com/computers
Consumer Electronics	www.ti.com/consumer-apps
Energy and Lighting	www.ti.com/energy
Industrial	www.ti.com/industrial
Medical	www.ti.com/medical
Security	www.ti.com/security
Space, Avionics and Defense	www.ti.com/space-avionics-defense
Transportation and Automotive	www.ti.com/automotive
Video and Imaging	www.ti.com/video

TI E2E Community Home Page

e2e.ti.com

Mailing Address: Texas Instruments, Post Office Box 655303, Dallas, Texas 75265
Copyright © 2011, Texas Instruments Incorporated